

INSTALLATION AND OPERATION MANUAL

MODEL NUMBERS: 25-PDVC , 55-SHP10 , & 55-TRP10

Thank you for purchasing this product from a fine line of heating equipment. We wish you many years of safe heating pleasure with your new heating appliance.

Save These Instructions.

NOTE: IF YOU HAVE A PROBLEM WITH THIS UNIT DO NOT RETURN IT TO THE DEALER. CONTACT CUSTOMER SERVICE @ 1-800-245-6489.

Questions? Need Parts or Options? www.englishstoveworks.com

Please Note the Following Precautionary Statements:

WE DO NOT RECOMMEND PELLET UNITS AS YOUR ONLY SOURCE OF HEAT.

England's Stove Works highly recommends the use of smoke detectors and Carbon Monoxide detectors with any hearth product, including this unit. Follow all manufacturer's instructions when using smoke or Carbon Monoxide detectors.

CAUTION: These units must be installed in accordance with the instructions and comply with your local building and fire codes. Please read this entire manual before installation and use of this pellet fuel burning room heater.

WARNING: USE OF OUTSIDE AIR IS MANDATORY WITH THIS UNIT.

**DO NOT OPERATE UNIT WITH HOPPER OPEN. LID MUST BE SHUT AND SECURED TIGHTLY.
*DO NOT OPERATE WITH DOOR OPEN. OPEN DOOR ONLY WHEN LIGHTING.***

The freestanding pellet units are approved for mobile home installation with outside combustion air hook-up. See "Flue System" section of manual.

CAUTION: The structural integrity of the mobile home floor, wall, and ceiling/roof must be maintained. Do not install in a sleeping room.

Mobile home installation should be in accordance with the Manufactured Home and Safety Standard (HUD), CFR 3280, Part 24.

→SAFETY NOTICE←

FAILURE TO FOLLOW THESE INSTRUCTIONS COULD RESULT IN PROPERTY DAMAGE, BODILY INJURY OR EVEN DEATH. FOR YOUR SAFETY AND PROTECTION, FOLLOW ALL THE INSTALLATION INSTRUCTIONS. CONTACT YOUR LOCAL BUILDING OR FIRE OFFICIALS FOR RESTRICTIONS AND INSTALLATION INSPECTIONS IN YOUR AREA.

Do not allow paint, chemicals or construction dust on or near your unit. Do not allow liquid or ANY foreign materials on or inside your unit. Shut your unit down and cover it when painting, construction or similar activity is taking place. Wipe and clean your unit after any construction is done in your home, or if any foreign material gets on or inside your unit. You may also need to remove the rear and side cover plates to your unit (unplug unit first) and vacuum and clean the motors and inside of your unit.



Rev. 4/03

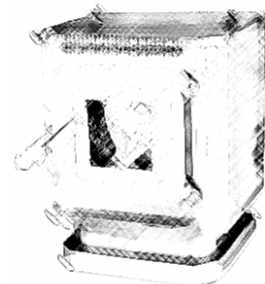

IMPORTANT INFORMATION

1. Check local installation codes for your area. Call your Homeowner's Insurance representative for inspection of your stove's installation.
2. Read and comply with the instructions in this manual.
3. This unit should be tested (dry run) before loading pellets for 30 minutes. The stove should automatically shut itself off after the 30-minute dry run.
4. **Your stove is designed to burn Premium Hardwood Pellets.** Pellets with a high ash content will burn dirty and the unit will need cleaning more often.
5. Be sure your pellets are not damp or wet. Keep sawdust out of the unit.
6. Use three-inch (3") U.L.-approved PELLET VENT TWIST-LOCK PIPE when installing this unit and follow the manufacturer's specifications for installation and clearances (we highly recommend Simpson Dura-Vent pellet twist-lock pipe). Even though this pipe interlocks, it is advisable to seal all connections with high temperature silicone. Use at least 3 screws to secure the pipe to the unit's exhaust blower. Also, if you do not use U.L.-approved twist-lock pellet pipe, be sure to use U.L.-approved Pellet Vent pipe, and fasten each joint of the pipe with at least three screws.
7. An outside combustion air connection is mandatory for this unit to work properly. Make this connection using a 1 ⁷/₈" I.D. metal pipe (steel, aluminum or copper; commonly found at muffler or auto shops) and coupler. Be sure to secure the pipe to the unit with a clamp or aluminum tape. The outside end should be covered (screened) to prevent any foreign matter from entering the system. Try to keep the number of bends in the pipe to a minimum. **NOTE:** If the total run of the connection exceeds 6', use 3" metal pipe (and coupler) instead.
8. Regularly inspect the burn pot area and, if any crust forms, remove it with a poker.
9. The ash in the burn pot should be removed regularly, depending on your burn rate. The area to the right and left of the burn pot is for ash storage; keep the air holes in the burn pot clean for a more efficient burn. Check your exhaust system frequently.
10. Keep pellets and all other combustible materials a safe distance from the stove.
11. This unit will require floor protection if it is installed on a combustible surface. The minimum floor protector for this stove is 36" x 36" which should give you at least one inch (1") of protection at the rear, four inches (4") on each side and six inches (6") minimum in the front of the unit.
12. Horizontal runs should not exceed four feet (4') with a max. vertical flue height of thirty-five feet (35'). At fifteen feet (15'), the pipe should be increased to 4" pellet vent pipe.
13. This unit should be turned off and allowed to cool prior to cleaning. Any ashes should be kept in an airtight metal container completely away from all combustibles and should not be disposed of until they are completely cooled.
14. Read the instructions thoroughly concerning the various settings that are available, including the digital read-out control board, and save them for future reference.

Visit our web site at www.englishstoveworks.com for helpful information, frequently asked questions, parts/accessory orders and more.

UNIT PREPARATION

Some dealers will prepare your unit for operation and even “dry run” it before delivery. If this has not been done, you can follow the steps as listed below.

1. Attach the spring handle to the door by turning it counterclockwise.
Important: Hopper Latches must be tight so that the top is sealed to prevent back-burn.
2. Test your 110-volt outlet for current and then plug in the unit. (**We highly recommend a surge protector for our pellet unit, as the control panel is electronic.**)
3. It is important to note that this stove is equipped with a dual auger system. The top auger runs intermittently and drops pellets to the bottom auger; the bottom auger runs constantly and simply pushes the pellets forward to the burn pot. The control board (“Heat Range”) setting determines the top auger feed rate.
4. The stove has a digital read-out control board and is started by pressing the “ON” touch pad. This will start the upper auger, bottom auger and exhaust blower. The room air blower will start later as the stove reaches the pre-set blower temperature (see “Control Board” section for further explanation).
5. Check to be sure both augers and the exhaust blower are operating before connecting the unit to the flue system.

FLUE SYSTEM

Caution: Follow the pipe manufacturer’s installation instructions and directions for passing through combustible walls and ceilings. Check local codes in your area.

Illustration 1

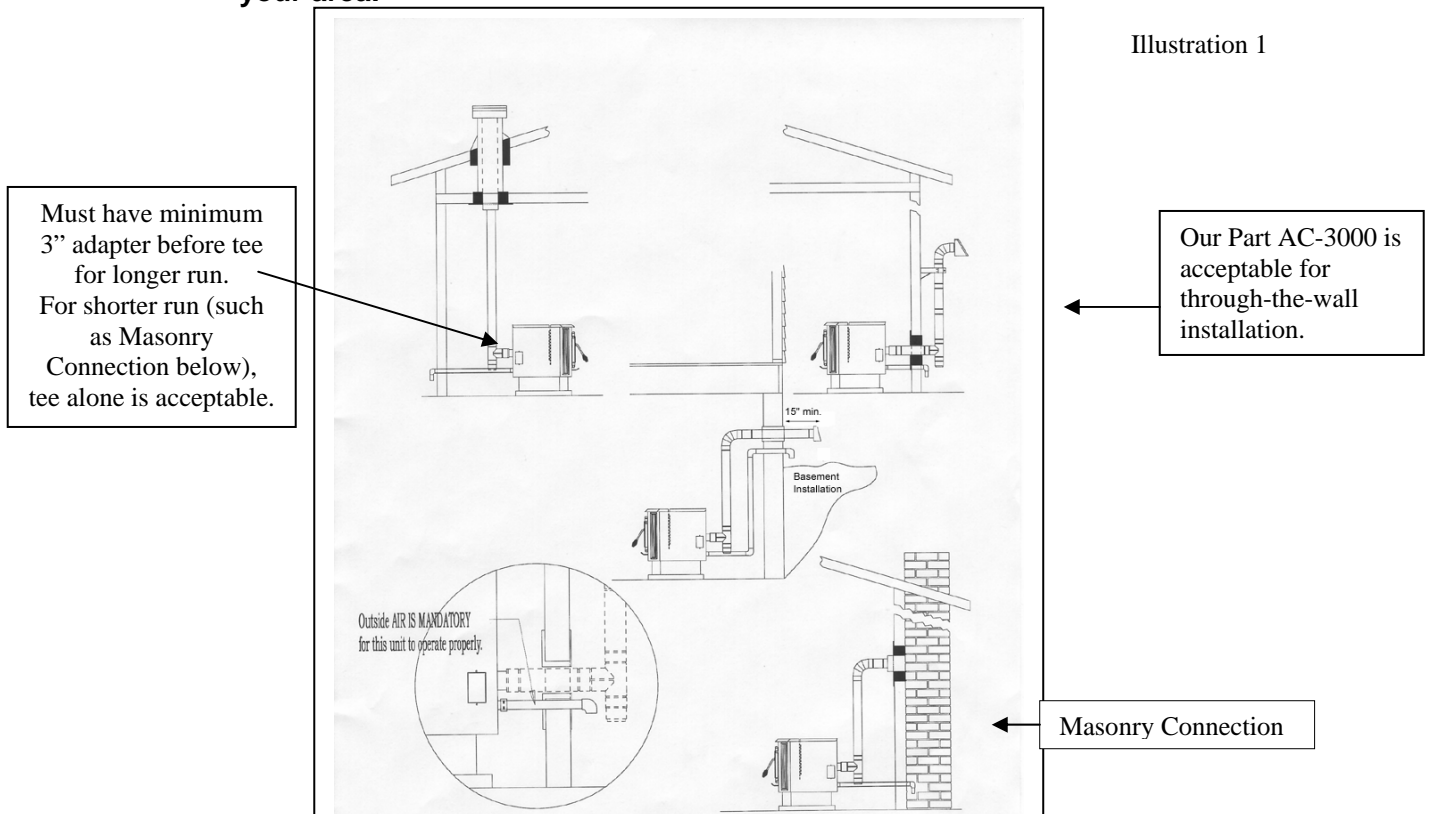

1. If 3” flue pipe exceeds 15’ in length, increase to 4” flue pipe for remaining flue connections.
2. Total flue length should not exceed 35’.
3. Horizontal run not to exceed 4’.
4. Floor protector required: Min. size 36” x 36”.
5. If the total run of outside air connection exceeds 6’, or if more than 2 elbows are used, use 3” metal pipe (and coupler) instead.
6. **Outside Air is mandatory for proper safe operation.**

This unit is equipped with a negative draft system that pulls air through the burn pot and pushes the exhaust out of the dwelling. If this unit is connected to a flue system other than the way explained in this manual, it will not function properly.

Pellet Vent Pipe

The UL approved pellet vent pipe that we recommend is a twist lock system; however, it is still recommended that high temperature silicone be used at each joint. England's Stove Works recommends the use of Simpson Dura-Vent® twist-lock pipe (if you use other pipe, consult your local building codes and/or building inspectors, and secure each joint with at least three screws—see Important Information, above). *Do not* use “B” vent gas pipe or galvanized pipe with this unit. The pellet pipe is designed to disassemble for cleaning and should be checked several times during the burning season. Pellet vent pipe is not furnished with the unit and must be purchased separately. **Do not install a flue damper of any kind in this system and do not connect this unit to a flue system serving another heating appliance.**

Through the Wall

To vent the unit through the wall, connect the pipe adapter to the exhaust motor adapter. If the exhaust adapter is at least eighteen inches (18”) above ground level, a straight section of pellet vent pipe can be used through the wall. Your dealer or our factory should be able to provide you with a kit that will handle most of this installation, which will include a wall thimble that will allow the proper clearance through a combustible wall. Once outside the structure, a three-inch (3”) clearance should be maintained to the outside wall and a clean out tee should be placed on the pipe that extends through the wall. We recommend a minimum of three feet (3') of vertical pipe with a 90-degree turn away from the house. At this point a one-foot (1') section should be added with a horizontal cap, which would complete the installation (*see Illustration 1*).

A wall strap should be placed just below the last 90-degree section to make the system more stable. If you live in an area that has heavy snowfall it is recommended the installation be taller than three feet (3') to get above the snowdrift line. This installation is only recommended for outside walls made of a non-combustible surface, such as brick or stone. This same installation can be used if your stove is below ground level by simply adding the clean-out section and vertical pipe inside until ground level is reached. With this installation you have to be aware of the snowdrift line, dead grass and leaves. We recommend a three foot (3') minimum vertical rise on the inside or outside of the house. The through-the-wall installation is the least expensive and simplest installation. Never terminate the end vent under a deck, in an alcove, under a window or between two windows.

Through the Ceiling

When venting the stove through the ceiling, the pipe is connected the same as through the wall, except the clean-out tee is always on the inside of the house, and a 3” adapter is added before the clean-out tee. You must use the proper ceiling support flanges and roof flashing that are supplied by the pipe manufacturer--follow the pipe manufacturer's directions and Illustration 1 in this manual. It is important to note that if your vertical runs of pipe are more than fifteen feet (15') at this point, the pellet vent pipe size should be increased to four inches (4”) in diameter. Do not exceed four feet (4') of pipe on a horizontal run, and do attempt to use the least number of elbows for your flue system. If an offset is used, it is better to install a 45-degree elbow whenever possible.

NOTE: Installing elbows may inhibit your draft by up to 15% per elbow.

NOTE on Mobile Home Installation:

Secure the heater to the floor using the two holes in the pedestal. If the unit is on a combustible surface, you will need to drill matching holes in the floor protection that you choose (see Floor Protection section). Do not disturb the structural integrity of the home, and be sure the unit is permanently electrically grounded to the chassis of your home. Remember that outside combustion air is mandatory, and not to install the unit in a sleeping room of the home.

***IMPROPER INSTALLATION: The manufacturer will not be held responsible for damage caused by the malfunction of a stove due to improper venting or installation. Call (800-245-6489) and/or consult a professional installer if you have any questions.**

Existing Flue System

If you are replacing a wood stove with a pellet unit the chimney or pipe should be cleaned thoroughly before proceeding with the installation. The flue system should be either masonry or a UL approved pre-manufactured Class A flue system. The flue thimble or pipe will be either six inches (6") or eight inches (8") and the proper reducer (6" to 3" or 8" to 3") and can be purchased or ordered by your local dealer. Connect a three inch (3") tee with clean-out to the pipe adapter -- seal this with a high temperature stove cement, then extend the pipe to the installed reducer at your thimble. If the thimble is in the ceiling the pipe will go straight up, but if the thimble is in the wall another 90-degree elbow will be required to make the connection.

Outside Air

Outside air is mandatory for this unit to operate properly. This unit has been designed and tested with this connection, because so many homes are airtight and there is not adequate combustion air available from inside the home. The air intake pipe is located at the rear of the burn pot and measures one and one half inches (1 ½") in diameter. This connection can be made with 1 7/8" metal pipe and coupler, and should exit through the wall or floor. Be sure to secure the pipe to the unit with a clamp or aluminum tape. The outside end of the pipe should be covered (screened) to prevent foreign matter from entering the system. If your unit is located below ground level, you will need to run the pipe up and then outside the dwelling. NOTE: If the total run of the connection exceeds 6', use 3" metal pipe (and coupler) instead.

FLOOR AND WALL PROTECTION

Floor Protection

If your floor is constructed of a non-combustible material such as brick or concrete there is no need for floor protection. If your floor is constructed of a combustible material such as hardwood, linoleum or carpet, then you will be required to use floor protection between the unit and the combustible. The protection that is chosen should be UL approved or equal, and should be large enough to provide a minimum of one inch (1") behind and four inches (4") on both sides of the stove. The clearance in front of the stove should be at least six inches (6"). This freestanding pellet unit will need a minimum 36" x 36" floor protector.

Wall Protection

From the rear and sides of the hopper only one inch (1") of clearance is required to paneling, wallpaper or sheet rock. The pellet vent pipe would require the standard three inches (3") clearance, or as recommended by the manufacturer. There should be at least six inches (6") of clearance to combustibles on the sides of the firebox – additional wall protection is seldom needed with this unit.

OPERATING INSTRUCTIONS

CAUTION: Do not operate with the door open; open door only when lighting.

Do not burn trash (paper bags, etc.) in this unit.

This stove has an induced draft system and is designed to operate continuously, as frequent shutdown is not required. The digital control board allows the stove to operate by a time delay-relay system; this system controls the top auger feed rate by operating for a predetermined number of seconds, while the bottom auger operates constantly. The setting of the "**Heat Range**" touch pad will control the heat output and the amount of pellets the unit will burn (see Ill. 2). Note: This stove is using solid fuel and will not restart automatically.

Horizontal Feed System

This unit has a top and a bottom auger that are separated by four inches (4"); a 1-RPM motor drives each auger. The top auger drops pellets to the bottom auger tube, and the bottom auger pushes the pellets forward to the burn pot. This assures there is no build up of fuel in the bottom auger tube. As pellets enter the burn pot the combustion air is drawn across the fuel.

START- UP PROCEDURE

Note: The operation of this unit should be checked (dry run) prior to this procedure.

1. Verify the hopper is clean and free of foreign matter and there is current at your outlet (we do recommend a surge protector be used with our unit).
2. Fill the hopper with wood pellets; do not allow any part of the bag or any foreign material in the hopper, as this may jam the augers. Close the hopper lid and secure the latches.
3. Place a handful of pellets in the burn pot, spread a small amount of fire starter over the handful of pellets and ignite them. Wait a few minutes before closing the door and pressing the "ON" touch pad on the control board -- if the door is closed before the pellets are burning thoroughly, the exhaust blower could put out the fire. If for some reason the unit does not come on after pressing the "ON" touch pad, the cord should be disconnected for two to three minutes. After this, the control board should reset and can be started again. If you still have problems, call our factory.
Recommended fire starter materials: Wax-impregnated wood chips, cardboard cubes or liquid fire starter designed for pellet stoves.
Never use gasoline, lantern fuel, kerosene, charcoal lighter fluid, diesel fuel or any other flammable liquid to start the fire.
4. Check to be sure the flame is sustaining itself and continues to increase. If the flame goes out, the procedure should be repeated.

First Fire: Adjust the "Heat Range" and "Blower Speed" to a "5" setting and allow the stove to operate in this manner for approximately three (3) hours (or more if necessary), allowing the stove to "cure out" as the paint and oils from the manufacturing process burn off. We recommend that you open doors and windows in your dwelling during this process.

Subsequent Cold Starts: We recommend that you operate the unit on a "5" setting until the convection (room air) blower begins to operate.

SHUT DOWN PROCEDURE

WARNING: NEVER SHUT DOWN THIS UNIT BY UNPLUGGING IT FROM THE POWER SOURCE. Refer to the instructions below.

Press the "OFF" touch pad to put the stove in the shut down mode. At this time the red light above the pad will illuminate. The instant this is done the top auger will stop feeding pellets to the bottom auger, but the room air blower, exhaust blower and the bottom auger will continue to operate. When the internal temperature of the unit drops to 95 degrees the room air blower will stop operating; the exhaust blower and the bottom auger will cease to operate when the temperature drops to 90 degrees. The red light will then shut off and the unit will be completely shut down. The hotter the unit is operating the longer it will take for the stove to complete the shut down cycle.

Note: If the room temperature stays above 70 degrees the unit will remain in the shut down mode for 54 minutes, regardless of the temperature at the heat sensor. If the stove stays on this long and you are sure the fire is out, the cord can be unplugged from the outlet. After approximately 10 seconds the unit can be connected to the power source and the control board will be reset.

DAILY OPERATION

Refueling the Unit

Always press the “OFF” pad before refueling. This unit has a 40-pound hopper and should be filled when the hopper level drops to three or four inches (3” or 4”).

Note: The hopper will be warm; therefore, you should always use some type of hand protection. Never place your hand near the auger while the stove is in operation.

Note: Be sure to close hopper **securely** before re-firing.

Power Outage

Important: This stove is equipped with a vacuum safety switch. If the power to your stove is interrupted for more than three minutes, but less than 18 minutes, the unit will shut down and an error code will show in the “Heat Range” window of the Control Board. At this point, you may press the “On” button and the unit will automatically resume operation; however, if the power is off for more than 18 minutes, the unit will have to be re-started completely (see “Start-Up Procedure). **NOTE:** The unit will also shut down in the event of Combustion Blower failure; if this is the case, the unit will not re-start and you must contact Customer Service at (800) 245-6489. It is very important for the unit to be vented properly (outside air), as the natural draft is needed to clear the smoke from the stove. Also, do not open the hopper lid. This may cause fire to burn in the hopper.

If the power is off for more than 18 minutes, use a poker or a scooper to place burning pellets in the sides of the firebox and remove them from the burn pot. When power is restored, press the “ON” button and let the unit run for approximately 5 minutes, then press the “OFF” button – this will remove any pellets from the upper and lower auger systems. After the unit has cooled, remove all remaining pellets from the firebox and burn pot area; you may then restart your unit.

Fire Outage

If the fire in the burn pot goes out, the unit will automatically enter the shut down mode.

Fuel Outage

If the unit should run out of pellets, or the pellets happen to bridge in the hopper, the temperature of the heat chamber will fall below 90 degrees and the stove will go into the shut down mode.

Combustion Blower Failure

If the combustion (exhaust) blower should fail on this unit the Vacuum Shut Down Switch will automatically stop the stove. This will shut your unit completely off, and there will be an “E” code in the “Heat Range” window on the control board. At this point you will need to contact Customer Service at (800) 245-6489. **NOTE:** It is very important for the unit to be vented properly (outside air hook-up), as the natural draft is needed to clear the smoke from the stove.

ASH REMOVAL AND DISPOSAL

Daily Ash Maintenance

If there is fuel in the hopper, press the “OFF” pad and allow the unit to burn for approximately five (5) minutes in the shut down mode prior to opening the front door. Use a long-handled

screwdriver or a long-handled putty knife to scrape off any build-up or crust in the burn pot area. This can be pushed to the left or right into the ash storage area.

Weekly Ash Removal

Shut the unit down by pressing the “OFF” pad and allowing the unit to go through the complete shut down cycle. Allow the unit to completely cool down and remove the ashes with a scoop. The ashes should be placed in a non-combustible container with an airtight lid and should always be placed on a non-combustible surface or on the ground until completely cooled and free of hot cinders. Once the ash is removed, the burn pot should be given a thorough inspection. Remove the burn pot wear plate (refer to the exploded diagram in the rear of this manual – Illustration 4) and check for any build-up in the front of the burn area. Clean out all air holes (if necessary a 1/8” drill bit can be used) --these air holes should be kept clean, as they supply combustion air under and around the pellet fuel.

Monthly Ash Removal

The large baffle plate (12” x 13”) that hangs above and behind the burn pot (refer to the exploded diagram in the rear of this manual – Illustration 4) should be removed monthly. This can be done by lifting up the plate and pulling it out. The area behind the plate should then be cleaned thoroughly, and the plate placed back in the original position. The burn pot assembly should also be thoroughly cleaned, and the wear plate should be removed and cleaned. Before replacing the wear plate, clean the burn box thoroughly.

Annual Cleaning

The stove and the flue system should be given a complete cleaning at the end of the heating season. Remove the burn pot assembly, clean it thoroughly, and re-install it (refer to Illustration 4); this will require new gasket for the burn pot. Be sure to tighten the set screws when you replace them, but do not over-tighten. In addition to the cleaning mentioned earlier, the exhaust blower should be removed annually and the blower tube vacuumed of any ash build up. When cleaning or replacing the blower a new gasket (Part # PU-CBG) should be added between the blower flange and the steel exhaust tube.

Soot and Fly ash: Formation and Need for Removal – The products of combustion will contain small particles of fly ash. The fly ash will collect in the exhaust venting system and restrict the flow of flue gases. Incomplete combustion, such as occurs during startup, shutdown, or incorrect operation of the room heater will lead to some soot formation which will collect in the exhaust venting system. The exhaust venting system should be inspected at least once every year to determine if cleaning is necessary.

MAINTENANCE

CAUTION: UNPLUG THIS UNIT PRIOR TO ANY SERVICE WORK.

SEE EXPLODED DIAGRAM (ILLUSTRATION 4) FOR PARTS REFERENCE

Note: To do any service on this unit the rear steel access panel must be removed. Eight (8) screws hold this panel to the rear of the stove.

Parts Orders: (800) 516-3636 www.englishstoveworks.com Questions: (800) 245-6489

Auger Motors

The auger motor and gearbox are one complete assembly (Part #PU-047040) and can be removed by disconnecting the power leads and loosening the (5/16” head) set bolt in front of the assembly. This bolt tightens down on the flat side of the gear shaft and locks the gear shaft and auger shaft together -- once the bolt is loosened, the entire assembly will slide from the locking collar. There are two motor assemblies on this unit and both rest on a shelf when not in operation. When replacing a motor, the assembly should always be placed on the shelf prior to starting the unit.

Auger Bearings and Auger Shafts

The auger bearings (Part #PU-UCF204-12) are a sealed unit and do not require lubrication. To replace the top auger all the fuel must be removed from the hopper, as well as the top auger assembly. Once this is done the four bolts that hold in the bearings can be removed. At this time, the complete auger assembly can be pulled from the stove. Loosen the two (2) set screws with a 1/8" allen wrench, which will disconnect the bearing from the shaft -- the bearing and auger shaft can be replaced by reversing this procedure. When placing the auger bearing and shaft assembly back into the unit, always tighten the four bolts in a diagonal pattern to ensure the bearings and shafts are aligned properly. *Follow the same procedure to work on the bottom auger*, with the exception that the pellets do not have to be removed from the hopper.

Convection Blower

The convection blower (room air blower) -- (Part #PU-4C442) is located on the left side of the unit and can be removed by disconnecting the power leads and removing the four mounting screws. Once this is done, the blower should slide out the rear of the unit. Reverse this procedure to install a new room air blower.

Combustion Blower

To clean or replace the combustion (exhaust) blower (Part #PU-076002B), the power leads and the pellet vent pipe must be disconnected. Next, remove the screws that hold the blower to the steel exhaust tube and the entire blower should release from the stove. The blower impeller, blower tube and the steel blower exhaust tube on the unit should be brushed and vacuumed. When cleaning or replacing the blower a new gasket (Part # PU-CBG) should be added between the blower flange and the steel exhaust tube.

Vacuum Switch

This unit is equipped with a Vacuum Shut Down Switch (Part # PU-VS), which helps control various functions of the unit. If an operational error occurs in the unit, the switch will shut the unit off, and an "E" (denoting "Error") will appear in the "**Heat Range**" window of the Control Board. Situations which could cause this include power failure, combustion blower failure, improper flue installation, a blocked flue (from rodents, nests, etc.), or "dirty burning" from burning improper fuel (see "Important Information" at the beginning of the manual).

Gaskets

This unit comes with a 3/4" rope gasket around the door, which should be replaced every two years. To replace the *door gasket* (Part #AC-DGKC), the old gasket must first be removed entirely -- this may require you to scrape the old material from the channel before adding the new cement. Once the new gasket and cement have been added, the door should be closed and latched for twenty-four hours to allow the adhesive to harden. If you are replacing the *window gasket* (Part #AC-GGK), the new gasket will already have adhesive on it. Remove the paper on the adhesive side and place the gasket around the outside edge of the glass, by forming a "U" with your fingers and placing the new material around the window. You should also replace the *combustion blower gasket* (Part # PU-CBG) whenever you remove or clean the combustion blower.

Finish

This new unit has been painted with 1200 degree Metallic Paint (Part #AC-MCSP) that should retain its original look for years. If the unit should get wet and rust spots appear, the spots can be sanded with plain steel wool and repainted. We recommend this paint, as others may not adhere to the surface or withstand the high temperatures.

Glass

This unit has a 9" x 9" ceramic glass (Part #AC-G9, comes with gasket) in the viewing door. If this glass becomes cracked in any area, the unit should be shut down and the window replaced with this high-temperature glass.

You may order parts and options on our web site: www.englishstoveworks.com,
or by calling (800) 516-3636.

Our web site also offers service instructions that can be printed or viewed as video.

Recommended Heat Ranges:

Low Burn:	Heat Range setting: 1	Room Air Blower setting: 1
Medium Low:	Heat Range setting: 2 – 3	Room Air Blower setting: *
Medium High:	Heat Range setting: 5 – 8	Room Air Blower setting: *
High Burn:	Heat Range setting: 9	Room Air Blower setting: 9

* NOTE: Blower Speed should match Heat Range setting.

PELLET UNIT CONTROL BOARD

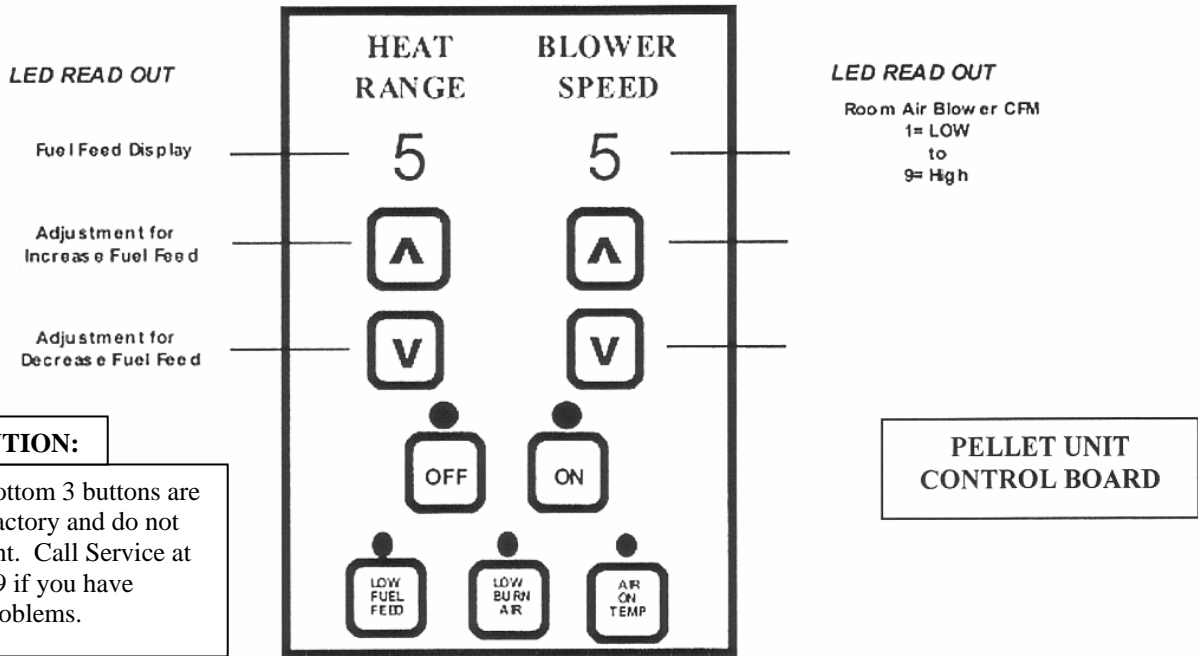

CAUTION:

NOTE: The bottom 3 buttons are pre-set at the factory and do not need adjustment. Call Service at (800) 245-6489 if you have questions or problems.

PELLET UNIT CONTROL BOARD

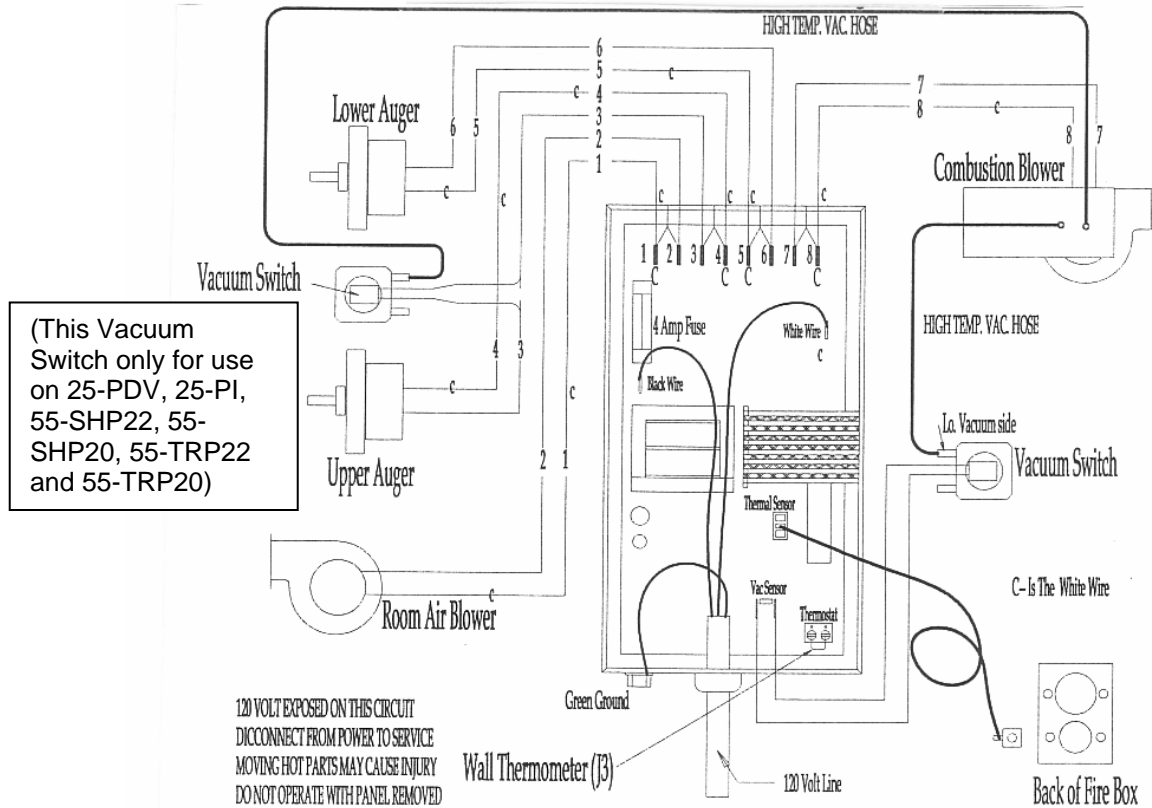

Illustration 2

The control board (PART #PU-CB98) is a digital read-out board. This board offers a wide variety of settings to operate the unit. The bottom controls are preset at the factory and should *not* require any changes on start-up of the unit. This part can be removed from the unit by loosening the two screws on the outside of the stove, and then pulling it back to the inside of the stove. The stove's rear access panel should be removed prior to removing the control board. A 4-amp fuse is used on this control board.

THERMOSTATS

REMOTE: There is now a Remote Thermostat (Part # AC-3001) available for your pellet stove. It comes with everything necessary for quick installation, and has many features to allow remote control of your unit.

WALL: Also, an external wall thermostat (such as our Part # GU-1E30-914) can be used on our pellet units as long as it is eight volts or less. After unplugging the unit, locate the jumper wire (J-3) on the bottom of the control panel. The two screws should then be loosened and the jumper wire removed from the board. Next, the two thermostat lead wires should be slipped into these openings and the screws tightened; the jumper wire should be saved for future operation without a thermostat.

The unit will operate differently once the wall thermostat is connected -- we recommend the stove control board be set at a minimum of "5" on the Heat Range while using the thermostat. This will allow the stove to run around a medium setting and drop back to a lower setting when the thermostat is not calling for heat. Refer to the section on "Start-up Procedure" for information on cold starts.

Call (800) 516-3636 or log onto www.englishstoveworks.com to inquire or order these.

HOPPER LID LATCHES

Illustration 3 –
Hopper Lid Latches

Important: Hopper Lid Latches must be checked periodically and kept tight so the top is sealed to prevent back-burn.

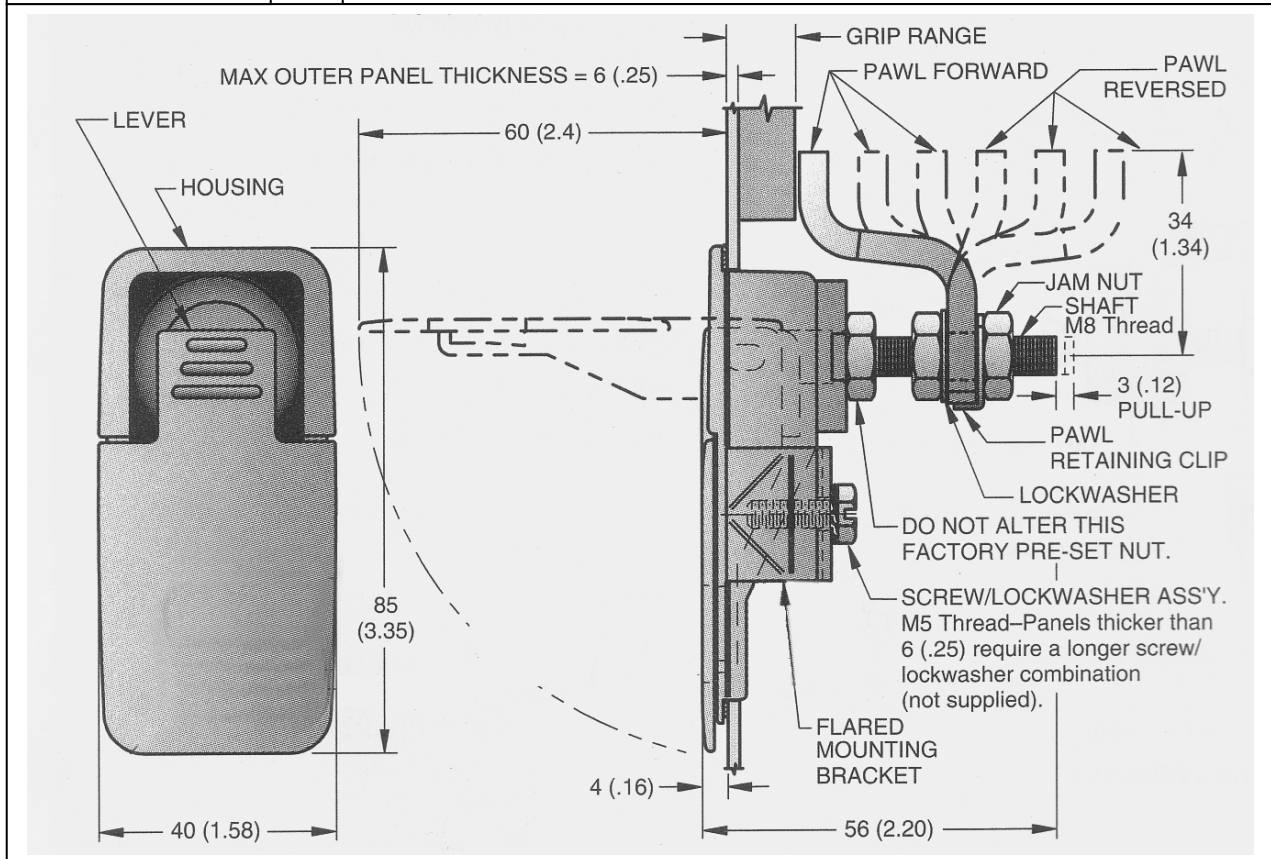

Have this information on hand if you phone the factory or your dealer regarding this product.

Retain for your files:

Model Number _____

Date of Purchase _____

Date of Manufacture _____ Serial # _____

LIMITED 5 YEAR WARRANTY FROM THE DATE OF PURCHASE TO THE ORIGINAL OWNER

The manufacturer extends the following warranties:

Five Year Period:

1. Carbon steel and welded seams in the firebox are covered for 5 years against splitting.
2. The cast iron door and hinges are covered for 5 years against cracking.

Three Year Period:

3. Component parts such as the hopper, auger burn pot, baffle plate, auger shafts, auger bearings, and fasteners are covered for 3 years against cracking, breakage and welded seams from separating.

One Year Period:

4. Electrical components, accessory items, glass and the painted surface are covered for 1 year from the date of purchase.

Conditions and Exclusions:

Damage from over-firing will void your warranty.

This warranty does not apply if damage occurs because of an accident, improper handling, improper installation, improper operation, abuse, or unauthorized repair made or attempted to be made.

The manufacturer is not liable for indirect, incidental, or consequential damages in connection with the product including any cost or expense providing substitute equipment or service during periods of malfunction or nonuse.

All liability for any consequential damage for breach of any written or implied warranty is disclaimed and excluded. Some states do not allow the exclusion or limitations of incidental or consequential damages, so the above may not apply to you.

Procedure:

Purchaser must give notice of claim of defect within the warranty period and pay transportation to and from a service center designated by the factory. The dealer from which the unit was purchased or the factory, at our option, will perform the warranty service.

Other Rights:

This warranty gives you specific legal rights, and you may also have other rights, which may vary from state to state.

NOTE: THIS WARRANTY IS NULL AND VOID IF YOU DO NOT RETURN THE ATTACHED WARRANTY REGISTRATION WITH A COPY OF THE SALES RECEIPT WITHIN 30 DAYS FROM THE DATE OF PURCHASE. WARRANTY IS NOT TRANSFERABLE

Pellet Stove Exploded View

NUMBER	PART DESCRIPTION
1	Door (Part # CA-19A)
2	Door Gasket (Part # AC-DGKC)
3	Glass with Gasket (Part # AC-G9)
4	Impingement Plate
5	Burn Pot <i>and</i> Wear Plate
6	Burn Pot Gasket
7	Side Access Panel
8	Combustion Blower
9	3" Blower Adapter
10	Gasket for Combustion Blower Part # PU-CBG
11	Pellet Feeder Pot
12	Digital Control Board
13	Convection Blower
14	Top Auger Bottom Auger
15	Block Bearing Gaskets
16	Block Bearings Part # PU-UCF204-12
17	3/4" I.D. Shaft Collars Part # PU-2X570
18	Auger Motors
19	Rear Access Panel
20	Hopper Flange Gasket Part # PU-HFG
21	Hopper
22	Hopper Lid Gasket Part # PU-HLG
23	Hopper Lid
24	Vacuum Shut Down Switch Part # PU-VS
25	Hopper Lid Latches
26	Brass Louvers (Certain Models only)

NOTE ON PART NUMBERS:

This diagram is a basic England's Stove Works pellet unit diagram. Your model may vary somewhat. See our online store at www.englishsstoveworks.com or the parts list in your manual for specific part numbers for your model stove. If a part is not listed in manual or on website, or if you have questions, call (800) 245-6489.

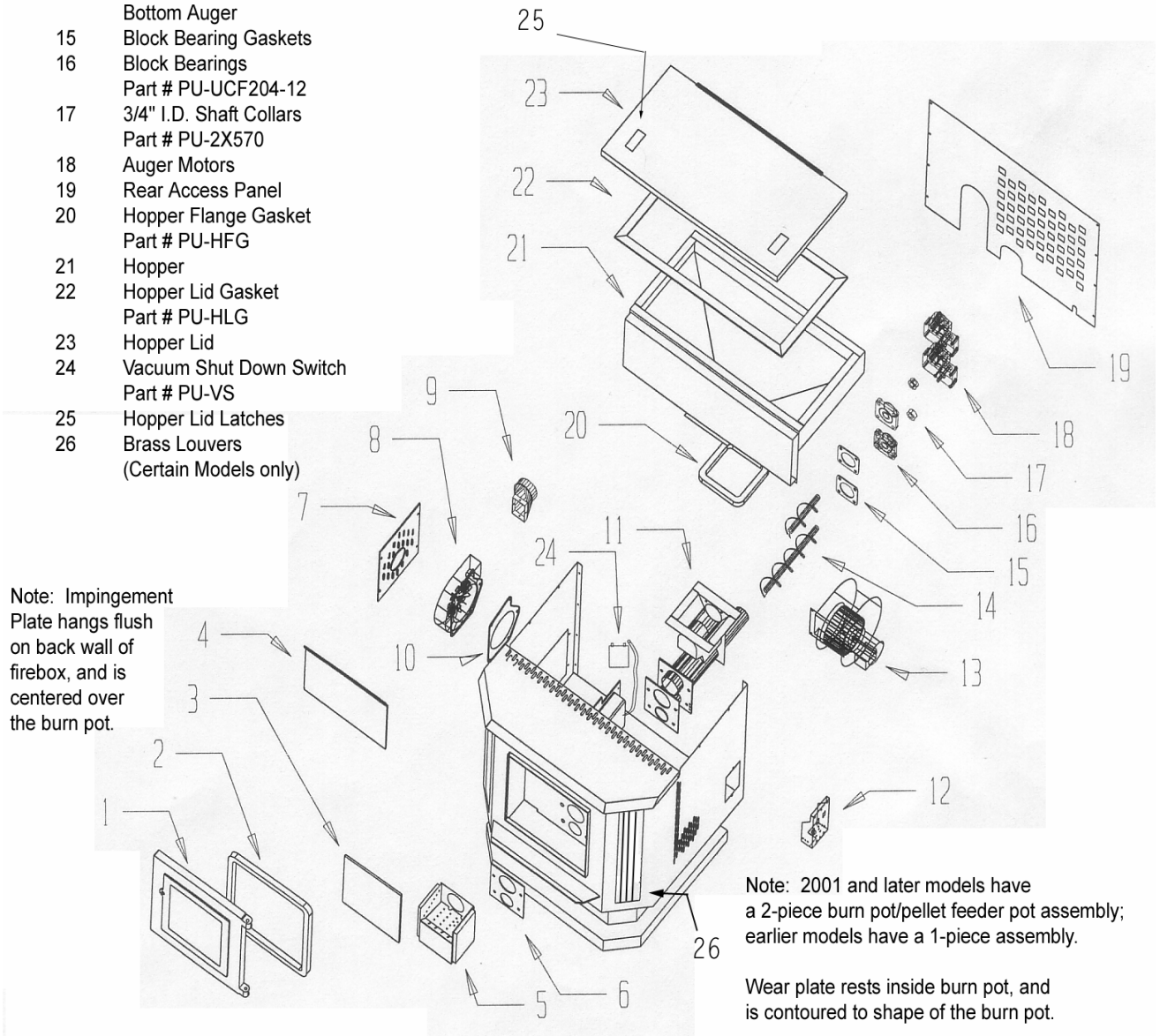

Note: Impingement Plate hangs flush on back wall of firebox, and is centered over the burn pot.

Note: 2001 and later models have a 2-piece burn pot/pellet feeder pot assembly; earlier models have a 1-piece assembly.

Wear plate rests inside burn pot, and is contoured to shape of the burn pot.

Dimensions of 25-PDVC/55-SHP10/55-TRP10: 23"W x 28"H x 21"D
(Approx. 13 1/2" from floor to center of exhaust)

Illustration 4

PARTS LIST FOR 25-PDVC, 55-SHP10 and 55-TRP10

AC-GGK	GLASS GASKET KIT (gasket only, no glass)
AC-DGKC	DOOR GASKET KIT (#2 on diagram)
AC-G9	9" X 9" GLASS <i>with</i> Gasket (#3 on diagram)
AC-SH	DOOR SPRING HANDLE
AC-MCSP PU-AMS PU-047040	HI-TEMPERATURE CHARCOAL PAINT AUGER MOTOR SUPPORT GASKET 1 R.P.M. AUGER MOTOR (#18 on diagram)
PU-076002B	COMBUSTION (Exhaust) BLOWER (includes 3" adapter) (#'s 8 and 9 on diagram)
PU-4C442	140 CFM CONVECTION BLOWER (#13 on diagram)
PU-CB98	DIGITAL CONTROL BOARD (#12 on diagram)
PU-62-40-151-3	Hopper Lid Latch (2002 and later Models; for earlier models order PU-103-50) (#25 on diagram)
PU-AF6T	TOP AUGER SHAFT W/FLIGHTING (#14 on diagram)
PU-AF11B	BOTTOM AUGER SHAFT W/FLIGHTING (#14 on diagram)
PU-BP98 (#'s 5 and 11 on diagram, call if you need only one part of this 2-piece assembly)	BURN POT ASSEMBLY
PU-VS	VACUUM SHUT DOWN SWITCH (# 24 on diagram)
PU-UCF204-12	AUGER BLOCK BEARING (#16 on diagram)
PU-2X570	¾" I.D. LOCKING COLLAR (#17 on diagram)
PU-ABG	AUGER BEARING GASKET
PU-HLG	HOPPER LID GASKET (#22 on diagram)
PU-CBG	COMBUSTION BLOWER GASKET (#10 on diagram)

OPTIONS

AC-3000	3" PELLET VENT KIT (Through the Wall)
AC-3001	REMOTE THERMOSTAT
AC-106-P/SH-106-P	BRASS WINDOW TRIM
AC-103	BRASS LIP TRIM FOR ASH APRON
GU-1E30-914	WALL THERMOSTAT

PARTS/OPTIONS ORDERS **ONLY**: (800) 516-3636
If you have any questions please contact our Customer Service Department:
CUSTOMER SERVICE & TECHNICAL CALLS: (800) 245-6489

Customer Service Department
P.O. Box 206
Monroe, Va. 24574

service@englanderstoves.com

(Fax: 434-929-4810)

You may also order parts and options, view frequently asked questions and more, on our web site: www.englishstoveworks.com

TROUBLE-SHOOTING GUIDE

WARNING: TO AVOID ELECTRICAL SHOCK ALWAYS *DISCONNECT* THE UNIT FROM THE POWER SOURCE BEFORE ATTEMPTING ANY REPAIR. IF THIS GUIDE DOES NOT CORRECT THE PROBLEM CALL YOUR LOCAL DEALER, OR OUR CUSTOMER SERVICE AT 1-800-245-6489.

<u>Problem</u>	<u>Cause</u>	<u>Solution</u>
1. Auger not turning	<ol style="list-style-type: none"> 1. Loose set screw 2. Bad gear motor 3. Foreign matter in auger 4. Vacuum sensor (Top Auger) 	<ol style="list-style-type: none"> 1. Tighten setscrew on collar 2. Replace auger motor 3. Remove pellets and object 4. Check exhaust blower
2. Smoke smell or dust in house	<ol style="list-style-type: none"> 1. Improper exhaust connection 	<ol style="list-style-type: none"> 1. Check all connections for leaks especially the exhaust blower connection; Seal with silicone, hose clamp or aluminum tape
3. Room air blower not operating	<ol style="list-style-type: none"> 1. Loose sensor 2. High "ON" temperature 	<ol style="list-style-type: none"> 1. Tighten connection on sensor 2. Adjust temperature lower
4. Exhaust blower not operating	<ol style="list-style-type: none"> 1. Loose connection 2. Bad blower 3. Bad vacuum sensor 	<ol style="list-style-type: none"> 1. Check connection at c/board 2. Replace blower 3. Replace vacuum sensor
5. Lazy fire	<ol style="list-style-type: none"> 1. Control board settings 2. Bad exhaust blower 3. Excessive pellet moisture 4. Excessive ash 5. Low quality pellets 	<ol style="list-style-type: none"> 1. Review board settings 2. Replace blower 3. Keep pellets inside 4. Remove baffles; Clean unit 5. Use premium hardwood pellets
6. Blown fuse (4 AMP)	<ol style="list-style-type: none"> 1. Power surge 2. Exposed wire 3. Electric motor shorting or bound up 	<ol style="list-style-type: none"> 1. Replace fuse; use surge protector 2. Check for exposed or frayed wire and loose connections 3. Check motors and blowers for obstructions or lock-up
7. High pellet consumption	<ol style="list-style-type: none"> 1. Low quality pellets 2. Board out of adjustment 	<ol style="list-style-type: none"> 1. Use premium hardwood fuel 2. Check c/board settings
8. Squeaking noise	<ol style="list-style-type: none"> 1. Build up in tube 2. Improper auger alignment 3. Blower noise 	<ol style="list-style-type: none"> 1. Remove auger and clean 2. Re-align auger 3. Remove and oil blower
9. Pinging or rattling noise	<ol style="list-style-type: none"> 1. Foreign material 2. Loose set screw 	<ol style="list-style-type: none"> 1. Check blower for material 2. Check impeller blower screw
10. Unit shuts down in 30 to 40 minutes	<ol style="list-style-type: none"> 1. Loose heat sensor 2. Control board settings 	<ol style="list-style-type: none"> 1. Check stove connection 2. Check settings; always start unit on "5" to "9" setting
11. Unit keeps shutting down ("E" code on control board)	<ol style="list-style-type: none"> 1. Blocked flue 2. Blower failure 3. Improper installation 	<ol style="list-style-type: none"> 1. Check for flue blockage (nests, rodents, excess soot, etc.) 2. Check combustion blower wires, call Cust. Svc. 3. Check for loose flue/pipe connections

Improper installation may cause a back draft.

***NOTE: Also check for loose or cracked vacuum hose on PU-VS switch (see #24 in Illustration 4).**

WARRANTY REGISTRATION

Purchased by (Name) _____

Address _____

City _____ State _____ Zip _____

Telephone _____

Email (Optional) _____

DEALER INFORMATION

Purchased From (Dealer) _____

Address _____

City _____ State _____ Zip _____

UNIT INFORMATION

Model Number _____ Purchase Date* _____

Serial Number _____ Mfg. Date _____

****A copy of your store receipt must accompany this registration form.***

IMPORTANT NOTICE

THIS REGISTRATION INFORMATION MUST BE ON FILE FOR THIS WARRANTY TO BE VALID. PLEASE MAIL THIS INFORMATION WITHIN THIRTY (30) DAYS FROM THE DATE OF PURCHASE.

Mail To:

England's Stove Works, Inc.
Customer Service Department
P.O. Box 206
Monroe, VA 24574

Or, Fax To:

(434) 929-4810 – 24 hours a day